

---

**AC POWER SUPPLY**

**APS-9301/9501/9102**

---

***User Manual***

**GW** **INSTEK**

## Contents

1.	<b>Safety terms and symbols</b> .....	<b>1</b>
2.	<b>Installation</b> .....	<b>2</b>
3.	<b>Operation</b> .....	<b>4</b>
4.	<b>Panel Description</b> .....	<b>8</b>
5.	<b>Calibration</b> .....	<b>11</b>
6.	<b>Circuit Principle</b> .....	<b>14</b>
7.	<b>Block Diagram</b> .....	<b>15</b>
8.	<b>Specification</b> .....	<b>16</b>
9.	<b>Maintenance</b> .....	<b>18</b>
9 1	Cleaning.....	18
9 2	Troubleshooting.....	18

## 1. SAFETY TERMS AND SYMBOLS

These terms may appear in this manual or on the product:



**WARNING:** Warning statements identify condition or practices that could result in **injury** or loss of life.



**Caution:** Caution statements identify conditions or practices that could result in damage to this **product** or other property.

The following symbol may appear in **this** manual or on the product:



Attention refer to Manual.

## 2. Installation

1. Before installation, please make sure the AC input voltage is correct.

a. The AC input voltage of APS-9301/9501 is either 115V or 230V, which can be selected. The select switch is located on the rear panel.

b. The AC input voltage of APS-9102 is either 115V or 230V, which can be selected. The select switch is inside the machine.

2. Before plugs input power cord to the suitable outlet or connects the input wires, please make sure all the APS-9301/9501/9102's breakers are turned off. It will avoid the unnecessary accident or damage to APS-9301/9501/9102.

3. Plugs the input power cord to the suitable outlet or connects the input wires/cable to the input terminal block which is located inside panel of APS-9301/9501/9102. Please make sure the connections are very tight which may avoid some problem happening.

4. Please make sure the input tolerance of this APS-9301/9501/9102 is within  $\pm 15\%$  of rated voltage (see figure 1)

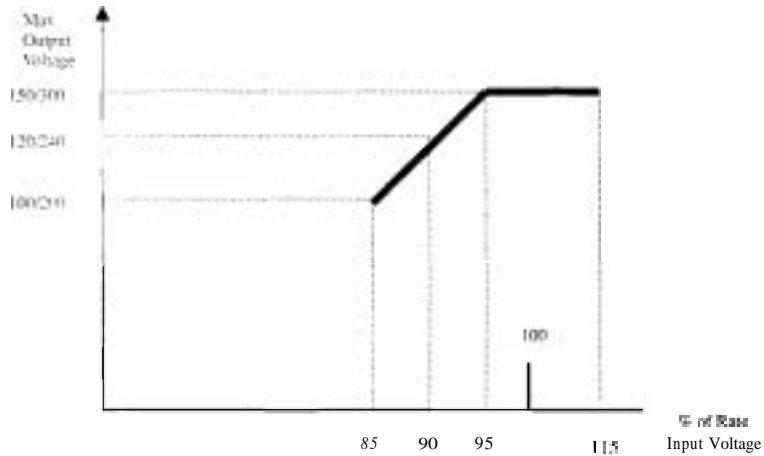

Figure 1

5. The size of input wire and output wire.

Model	Input Wire Size (mm <sup>2</sup> )		Output Wire Size (mm <sup>2</sup> )
	115V	230V	
APS-9301/9501	3.5		AWG#12
APS-9102	5.5	3.5	2

6. An AC power cord is packaged in the unit of APS-9301/9501 as accessory, but not available for APS-9102.

### 3. Operation

#### 1.Voltage Setting:

Voltage setting contents '110V', '220V', 'A' and '▼' four keys

- a. When any one of the keys mentioned above is pressed, the voltage display will flash one time, the APS9301/9501/9102 will go to the setting mode and show the voltage setting value.
- b. If the '110V' Key is pressed, the output voltage will be adjusted to 110V immediately. Meanwhile, the voltage display will switch back to the reading mode automatically.
- c. If the '220V' key is pressed for 0.2 seconds continuously ( for safety reason, must be), the output voltage will be adjusted to 220V. Meanwhile, the voltage display will switch back to the reading mode automatically.  
**Note:** It would not work if the output voltage is setting on low range. (100-150V output)
- d. If either "▲" or "▼"key is pressed for 0.5 seconds continuously, the output voltage will be adjusted. If either "▲" or "▼" is pressed twice continuously, the output voltage will be adjusted immediately.
- e. The adjusting rates are 0.1V/step on fine adjust mode and 1V/step on course adjust mode.
- f. The first six steps of adjustment will be spent 0.25 seconds per step. If the key "▲" or "▼" is pressed continuously, it will spend 0.13 second per step for the rest steps. If the key is released, the voltage adjustment would be stopped and go back to the original adjustment speed (0.25seconds per step) automatically.
- g. If the output mode is setting ON, the indicator 'OUTPUT' would light, the output voltage could follow the setting voltage simultaneously

**Caution:** If there is no function test of voltage '▼' or '▲', the voltage output mode would be suggested to switch to 'OFF' status for avoiding unnecessary mistakes occurring.

- h. If any key mentioned above is not pressed for 2 seconds continuously, APS-9301/9501/9102 would go back to the normal operation and the voltage display could show the reading value automatically.

#### 2.Frequency Setting:

Frequency setting contents '50Hz', '60Hz', '▲' and '▼' four keys

- a. Either the key '50Hz' or the key '60Hz' is pressed, the frequency will be changed immediately to 50Hz, 60Hz respectively. Meanwhile the output frequency will be changed coincidentally.
- b. The frequency ranges from 45Hz to 99.9Hz can be adjusted by 0.1 Hz per step in fine adjustment mode and 1 Hz per step in coarse adjustment mode. The frequency ranges from 100Hz to 500Hz can be adjusted by 1 Hz per step in fine adjustment and 10Hz per second in coarse adjustment mode.
- c. The other setting are same as voltage setting

#### 3.High / Low Voltage range selection:

Press the key of 'RANGE'. if the indicator lights, the output voltage would be setting on the high voltage range. otherwise, the system would be setting on low voltage range. The changed range would not cause the setting voltage to change, however, there is a 20ms interruption during the voltage range changing. The non-reasonable range changing (For example, the voltage sets 200V but the range is changed to the low range) is not acceptable by APS-9301/9501/9102.

**Note:** High range voltage 0 - 300V  
Low range voltage 0 - 150V

#### 4.Instrumentation selection:

- a. Press the key of 'A', the indicator of current will light and the LED display will show the value of current.
- b. Press the key of 'W', the indicator of power will light and the LED display will show the value of wattage.
- c. Press the key of 'PF', the indicator of power factor will light and the LED display will show the value of power factor.

5. Output Enabled and Disabled Operation:

Press the key of 'OUTPUT'. If the indicator of output lights, the output of APS-9301/9501/9102 is enabled. all the LED display will show the output value (reading value). Otherwise, the output function is disabled, and the LED display will show the setting value. Press the 'OUTPUT' key again to change the mode.

6. Lock Function:

Press the key of 'LOCK'. If the indicator of lock lights, all the keys are Locked (except the alarm reset). This function is good for avoiding any mistakes of key pressed during operation. Press again to change the mode.

7. Alarm Reset:

If there is over current happened. APS-9301/9501/9102 would be shut down and buzz immediately. You must press the key of 'ALARM RESET' to clear the fault of over current and stop the buzz. In addition, the key of 'OUTPUT' have to be pressed to get the normal output voltage again.

8. Memory Function:

As APS-9301/9501/9102 is equipped with EEPROM, the latest setting will be memorized after the unit is turned off. If the APS-9301/9501/9102 is turned on again, the latest setting will be displayed.

9. Save/Recall Function:

b. Press the key of 'SIR'. if the indicator of SAVE/RECALL doesn't light, Press any one of keys 'MEM1' 'MEM2' 'MEM3' and 'MEM4' for 0.2 seconds, the current output setting will be saved. If the indicator of SAVE/RECALL lights, press any one of keys 'MEM1' 'MEM2' 'MEM3' and 'MEM4' for 0.2 seconds, the setting saved last time via the same key will be recalled as current setting.

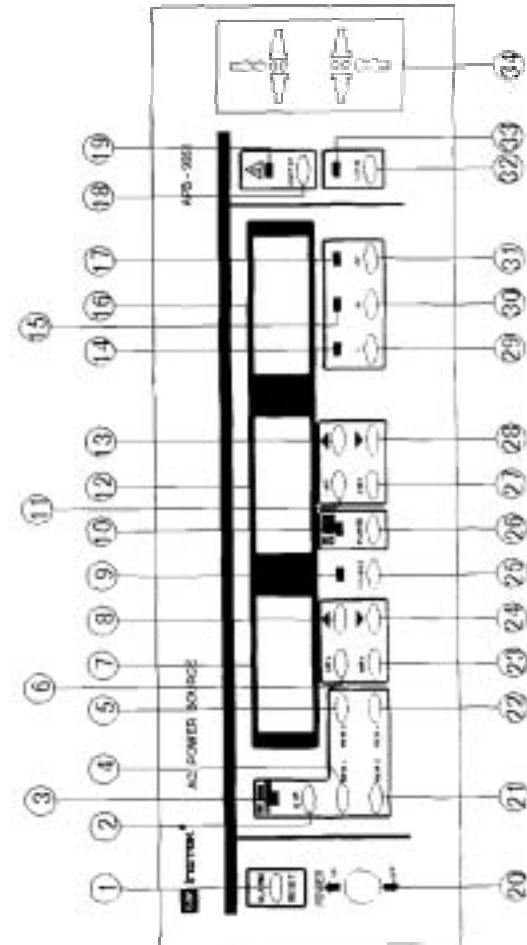

## 4. Panel Description

### (1) 'ALARM RESET' Kej

Reset key to cease the buzz and reset the output.

### (2) 'SIR' Key

Same as Recall function selecting key

### (3) SAVE/RECALL indicator

In the mode to save setting, the indicator doesn't light. In the mode to recall setting, the indicator lights.

### (4) (51, (21), (22) 'MEM1' 'MEM2' 'MEM3' 'MEM4' keys

When the SAVE/RECALL indicator is off, the four keys are for saving four different settings. When the indicator are on, the keys are for recalling the saved settings.

### (6), (23) '50Hz', '60Hz' Keys

One touch key for 50Hz and 60Hz output respectively.

### (7) Output Frequency LED Display:

If the 'OUTPUT' key isn't pressed, the indicator doesn't light, and the setting frequency value will be displayed on the output frequency LED display. If the 'OUTPUT' key is pressed, the indicator light, and the output frequency value will be displayed on the output frequency LED display.

### (8), (24) '▲' '▼' Keys

The two keys are for frequency setting, to increase or decrease the frequency value respectively every time they are pressed. The adjusting rate depends on the 'COARSE' key and the frequency value itself.

### (9) Coarse Indicator

If the coarse adjustment mode is selected, the coarse indicator will light. If the fine adjustment mode is selected, the coarse indicator does not light.

### (10) High / Low Range Indicator of Output Voltage

If this indicator lights, the output voltage is in the range 0 - 300V. If this indicator does not light, the output voltage is in the range 0 - 150V.

### (11), (27) '110V', '220V' Keys

One touch key for 220V and 110V output respectively

### (12) Output Voltage LED Display

If the 'OUTPUT' Key is not pressed, the indicator doesn't light, and the setting value will be displayed on the Output Voltage LED Display. If the 'OUTPUT' key is pressed, the indicator lights, and the output value will be displayed on the Output Voltage LED Display.

### (13), (28) '▲', '▼' keys

The two keys are for voltage setting, to increase or decrease the voltage value respectively every time they are pressed. The adjusting rate depends on the 'COARSE' key.

### (14) Function of Ammeter Indicator

If ammeter's indicator lights, the value of output current will be displayed on the multimeter LED display.

### (15) Function of Wattage Meter Indicator

If wattage meter's indicator lights, the value of output wattage will be displayed on the multimeter LED display.

### (16) Multimeter LED Display

The value of output current, wattage or power factor will be displayed by respective key from 'A', 'W', to 'PF'.

### (17) Function of Power Factor Meter Indicator

If power factor meter's indicator lights, the value of output power factor will be displayed on the multimeter LED display.

### (18) 'OUTPUT' Key

Output function enabled/disabled selection key.

### (19) Output Indicator

When output is enabled, the output indicator will light.

### (20) Power Switch

To turn on /off APS9301/9501

### (25) 'COARSE' Key

Coarse/Fine adjustment selection key.

### (26) 'RANGE' Key

For the high / low output voltage's range selection.

(29) 'A' Key

Ammeter selection key of multimeter LED display

(30) 'W' Key

Wattage meter selection key of multimeter LED display.

(31) 'PF' Key

Power factor meter selection key of multimeter LED display.

(32) 'LOCK' Key

Lock / Cnlock keyboard selection key

(33) Lock Indicator

The lock indicator lights to indicate the keyboard is locked. All other keys except 'RESET' are disabled.

(34) Outlet

Output socket



**Caution:**

**The maximum AC voltage is up to 300V. Do not touch the output sockets when the OUTPUT indicator appears lit.**

## 5. Calibration

The calibration of APS-9301/9501/9102 has been done in the factory. If it is necessary to do the calibration again, the procedures can be followed as:

1. Check if the APS-9301/9501/9102 works normally. Then turn off the APS-9301/9501/9102.

2. Press the 'LOCK' key continuously meanwhile turn on the APS-9301/9501/9102. The key of 'LOCK' must be pressed for 2 seconds at least until the LED Display steady. Then APS-9301/9501/9102 is in the calibration mode.

3. Selection of APS-9301, APS-9501 and APS-9102

Use the 'A' key of frequency to choose the correct mode of APS series.

The numbers are as following:

00: means APS-9301

01: means APS-9501

02: means APS-9102

### 4. Voltmeter Calibration

a. Press the 'PF' key, the APS-9301/9501/9102 will offset the voltmeter and provide a approximate 240V's output voltage.

b. Connect a standard true RMS voltmeter to the output socket of APS-9301/9501/9102

c. Use the key '▲' and '▼' of voltage to adjust the APS-9301/9501/9102's output voltage till to 240V exactly.

d. Press the key 'LOCK'. the calibration is completed.

### 5. Ammeter Calibration

There are low and high ranges calibration for ammeter

#### A. Low range calibration

1) Make sure the Coarse indicator is extinguished. If the coarse indicator appears lit, press 'COARSE' key to put out the indicator.

2) Press the key 'A', APS-9301/9501/9102 will offset the low range of

ammeter and provide a 110V's output voltage automatically.

3) Connect a standard true RMS ammeter and variable resistor to the output socket of APS-9301/9501/9102.

4) Adjust the APS-9301/9501/9102's output voltage or the variable resistor till to get 1.8A exactly seen from the true RMS ammeter.

5) Press the key '**LOCK**', the calibration of the low range of ammeter of APS-9301/9501/9102 is completed.

#### B. High range calibration

1) Make sure the Coarse indicator appear lit. If not, press the key '**COARSE**' to turn on the indicator.

2) Press the key '**A**'. APS-9301/9501/9102 will offset the high range of ammeter and provide a 110V's output voltage automatically.

3) Connect a standard true RMS ammeter or a variable resistor to the output socket of APS-9301/9501/9102

4) Adjust the APS-9301/9501/9102's output voltage or the variable resistor till to get 2.5A(9301) /4A(9501) /8.0A(9102) seen from the true RMS ammeter.

5) Press the key '**LOCK**', the calibration of the high range of ammeter of APS-9301/9501/9102 is completed.

#### 6. Wattage Meter Calibration

There are low and high ranges calibration for wattage meter

##### A. Low range calibration

1) Make sure the Coarse indicator is extinguished, if not, press key '**COARSE**' to put out the indicator.

2) Press the key '**W**'. APS-9301/9501/9102 will offset the low range of wattage meter and provide a 240V's output voltage automatically.

3) Connect a standard true RMS wattage meter and a variable resistor to the output socket of APS9301/9501/9102.

**Note: The closer the voltage sensing point of wattage meter is to the Output socket, the better.**

4) Adjust the APS-9301/9501/9102's output voltage or the variable resistor till to get 300W seen from standard RMS wattage meter exactly.

5) Press the key '**LOCK**', the calibration of the low range of wattage meter of APS-9301/9501/9102 is completed

##### B. High range calibration

1) Make sure the coarse indicator appear lit. If not, press the key '**COARSE**' to turn on the indicator.

2) Press the key '**W**', APS-9301/9501/9102 will offset the high range of wattage meter and provide a 110V's output voltage automatically.

3) Connect a standard true RMS wattage meter and a variable resistor to the output socket of APS-9301/9501/9102

**Note: The closer the voltage sensing point of wattage meter is to the Output socket, the better.**

4) Adjust the APS-9301/9501/9102's output voltage or the variable resistor till to get 300W(9301) / 450W(9501) / 900W(9102) seen from the standard RMS wattage meter exactly.

5) Press the key '**LOCK**', the calibration of the high range of wattage meter of APS-9301/9501/9102 is completed.

7. Turn off the input circuit breaker of APS-9301/9501/9102 after the calibration

is completed. Then turn on the input circuit breaker again, the APS-9301/9501/9102 will operate normally.

8.Each function of calibration is independent. If only one or two items need to be calibrated, it is not necessary to calibrate all the items.

9.If the calibration have to be interrupted during the calibration procedure, you can press the key of 'PF', 'A', or 'W' of the voltmeter, ammeter, or wattage meter respectively to stop the calibration.

10.If the calibration can not be processed, please call for service



## 6. Circuit Principle

The APS series products are controlled by CPU and operated via keyboard. The APS series are fully digital controlled.

The input isolate transformer has been applied to isolate the city power from the AFS series. And step down the input voltage for appropriate applications. The main AC power is rectified and filtered to become a very smooth DC source for power amplifier. Sine wave form is generated by the digital synthesizer and filtered by a very high impedance filter. Therefore, the sine wave form will be very stable and the distortion will be reduced.

The APS series have two voltage feedback systems. One is analog feedback system for quick response (within 100 $\mu$ s), and the regulation will be located in the range of  $\pm 5\%$ . The other is digital feedback system. The system will read the output voltage and compare with the settings. The accuracy of output voltage will be limited in the range of  $\pm 0.1V$ .

The sine wave signal is amplified by power amplifier. The power amplifier provides a very clean and low distortion sine wave to the output of APS series through the output transformer. The offset and calibration data of instrumentation are stored in the EEPROM. The instrumentation would be calibrated automatically when the APS series is switched on. True RMS circuit is applied for the voltmeter and ammeter. The value of LED display is true RMS value.

For easy operation, the APS series equips a memory of EEPROM. The EEPROM will memorize the latest settings data automatically after the APS Series have been switched off. If the APS series is switched on again, the CPU could read all the data from the EEPROM and provide the output value same as the previous setting. It is unnecessary to reset the data after APS series are switched off.

## 7. Block Diagram

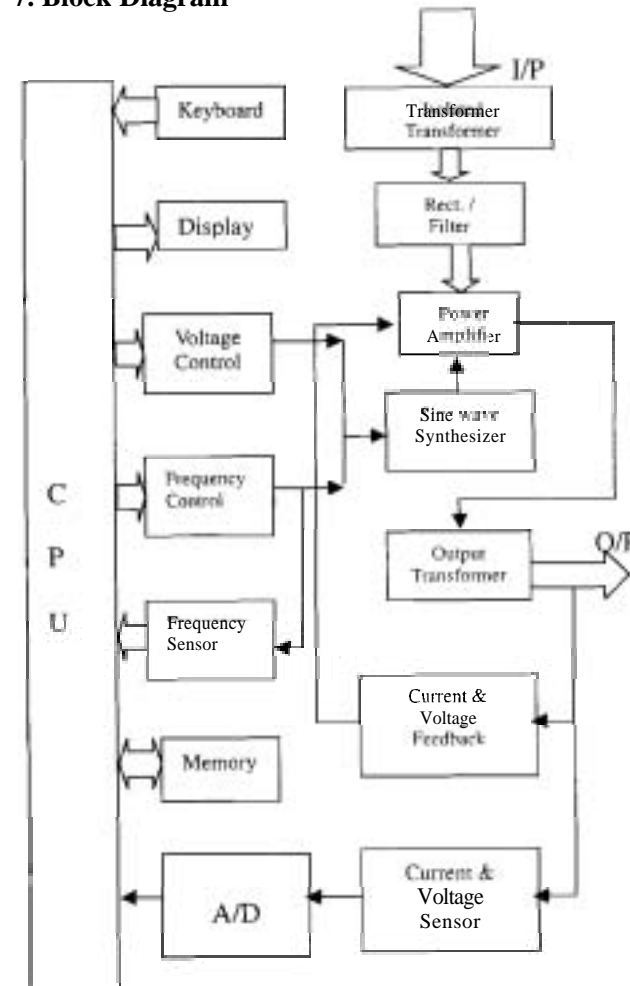

### 8 Specifications

This section contains a table of APS-9301/9501/9102 characteristics.

Table 1: Specification

Specification	Description
Output Frequency (5.0 - Hz)	Digital setting via keys. Resolution: 0.1Hz Accuracy: ±0.1Hz
Output Voltage (AC0.0 - 300.0V)	Digital setting via keys. Resolution: 0.1Vrms Accuracy: ±0.1%rdg+1digit
Output Capacity	Low voltage range: 0.0 - 150Vac High voltage range: 0.0 - 300Vac
Output Power	300VA(9301); 500VA(9501); 1KVA(9102)
Maximum Current	APS-9301: 2.6A(0~150V), 1.3A(0~300V) APS-9501: 4.2A(0~150V), 2.1A(0~300V) APS-9102: 8.4A(0~150V), 4.2A(0~300V)
Line Voltage Regulation	±0.1%
Load Regulation	±(0.5%+0.1V)
Protection	Key Lock, OCP, Short
Frequency Stability	±100PPM
Wave Distortion	±0.5%THD (Resistance Load)

Digital Display:	
Frequency Counter	Measuring Range: 0.0~999Hz Resolution: 0.1Hz Accuracy: ±0.1Hz
RMS Voltmeter	Measuring Range: AC0.0 - 380V Resolution: 0.1Vrms Accuracy: ±1% Rdg+1Digit
RMS Ammeter	Measuring Range: 0.000~2.000A 1.80 - 35.00A Resolution: 1mA 0.01A Accuracy: ±1% Rdg+5Digits ±1% Rdg+2Digit
Wattage Meter	Measuring Range: 0.0~360W 320 - 3500W Resolution: 0.1W 1W Accuracy: ±1.5% Rdg+5Digits ±1.5% Rdg+1Digit
Power Factor Meter	Measuring Range: 0.000 - 1.000 Resolution: 0.001 Accuracy: ±2% rdg + 2 digits
Line Input Requirement	115/230Vac±15 9.47-63Hz, 1 phase
Calibration	Front Panel Software Calibration
AC Power consumption	Maximum 2.1KW
Operation Environment	Indoors Rated Temperature: +10°C ~+35 °C Operating Temperature: +0 °C ~+40 °C Storing Temperature: -10°C ~+70 °C Relative Humidity:<80%
Accessory	Operation manual.....x1 Line cord.....x1(APS-9301/9501)
Dimensions	137mm(H) x 430(W) x 500mm(D) (APS-9301/9501) 225mm(H) x 430(W) x 500mm(D) (APS-9102)
Weight	Approximate 20/25/35kg (APS-9301/9501/9102)

## 9. Maintenance

This section includes the basic maintenance information for APS-9301/9501/9102

### 9.1 Cleaning

To clear APS-9301/9501/9102, use a soft cloth moistened with a small amount of

Water or mild detergent. Do not spray cleaner directly onto the instrument, since it may leak into the cabinet and cause damage.

Do not use chemicals containing benzene, xylene, acetone, toluene, or similar solvents.

Do not use abrasive cleaners on any portion of this equipment

### 9.2 Troubleshooting

Troubleshooting here of the APS-9301/9501/9102 is limited to check the input power fuse. If you have other difficulties of operation with your APS-9301/9501/9102, please contact the Good-Will representative for help.



**Warning:** To avoid electrical shock, the power cord protective

Grounding conductor must be connected to ground.



**Warning:** To avoid fire. Please use fuse of the specified type and rate, and disconnect the power cord before replacing the fuse.